

1.25Gb/s SFP BIDI 160km Optical Transceiver Module HTSF-B1G5549Yx

Features

- Up to 1.25Gb/s data links
- 1550nm DFB laser transmitter and APD photo-detector
- Up to 160km on 9/125μm SMF
- Hot-pluggable SFP footprint
- BIDI LC/UPC type pluggable optical interface
- Low power dissipation
- Metal enclosure, for lower EMI
- RoHS compliant and lead-free
- Support Digital Diagnostic Monitoring interface
- Single +3.3V power supply
- Compliant with SFF-8472
- Case operating temperature
Commercial: 0 ~ +70°C
Extended: -10 ~ +80°C
Industrial: -40 ~ +85°C



Applications

- Switch to Switch Interface
- Gigabit Ethernet
- Switched Backplane Applications
- Router/Server Interface
- Other Optical Links

Part Number Ordering Information

Part Number	Data Rate (Gb/s)	Wavelength (nm)	Transmission Distance(km)	Temperature (°C) (Operating Case)
HTSF-B1G5549YC	1.25	1550Tx/1490nmRx	160km SMF	0~70 commercial
HTSF-B1G5549YE	1.25	1550Tx/1490nmRx	160km SMF	-10~80 Extended
HTSF-B1G5549YI	1.25	1550Tx/1490nmRx	160km SMF	-40~85 Industrial

1. Absolute Maximum Ratings

It has to be noted that the operation in excess of any individual absolute maximum ratings might cause permanent damage to this module.

Parameter	Symbol	Min	Max	Unit	Notes
Storage Temperature	T _s	-40	85	°C	
Power Supply Voltage	V _{CC}	-0.3	3.6	V	
Relative Humidity (non-condensation)	RH	5	95	%	
Damage Threshold	TH _d	0		dBm	

2. Recommended Operating Conditions and Power Supply Requirements

Parameter	Symbol	Min	Typical	Max	Unit	Notes
Operating Case Temperature	T _{OP}	0		70	°C	commercial
		-10		80		extended
		-40		85		industrial
Power Supply Voltage	V _{CC}	3.135	3.3	3.465	V	
Data Rate			1.25		Gb/s	
Control Input Voltage High		2		V _{CC}	V	
Control Input Voltage Low		0		0.8	V	
Link Distance (SMF)	D			160	km	9/125um

3. General Description

HTF'HTSF-B1G5549Yx Small Form Factor Pluggable (SFP) transceivers are compatible with the Small Form Factor Pluggable Multi-Sourcing Agreement (MSA), The transceiver consists of five sections: the LD driver, the limiting amplifier, the digital diagnostic monitor, the DFB laser and the APD photo-detector .The module data link up to 160km in 9/125um single mode fiber.

The optical output can be disabled by a TTL logic high-level input of Tx Disable, and the system also can disable the module via I2C. Tx Fault is provided to indicate that degradation of the laser. Loss of signal (LOS) output is provided to indicate the loss of an input optical

signal of receiver or the link status with partner. The system can also get the LOS (or Link)/Disable/Fault information via I2C register access.

4. Pin Assignment and Pin Description

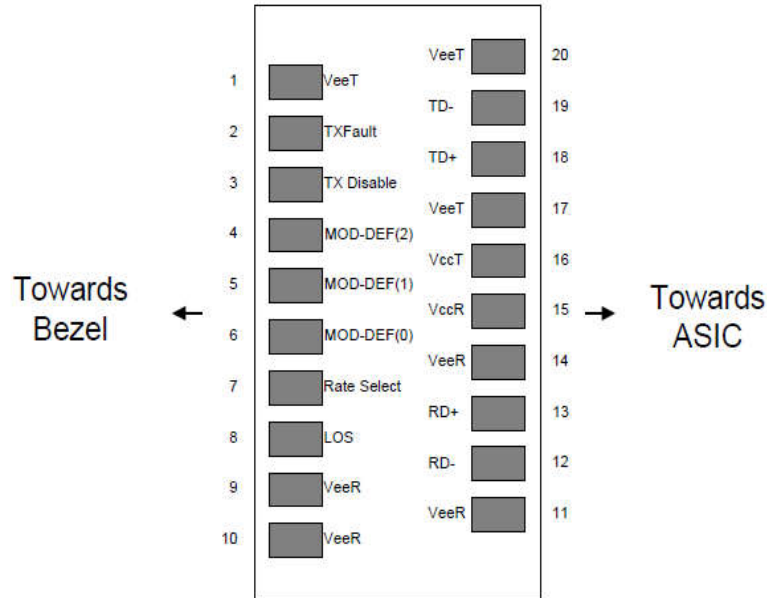

Figure1. Diagram of host board connector block pin numbers and names

PIN	Name	Name/Description	Notes
1	VEET	Transmitter Ground (Common with Receiver Ground)	1
2	TXFAULT	Transmitter Fault.	
3	TXDIS	Transmitter Disable. Laser output disabled on high or open.	2
4	MOD_DEF(2)	Module Definition 2. Data line for Serial ID.	3
5	MOD_DEF(1)	Module Definition 1. Clock line for Serial ID.	3
6	MOD_DEF(0)	Module Definition 0. Grounded within the module.	3
7	Rate Select	No connection required	4
8	LOS	Loss of Signal indication. Logic 0 indicates normal operation.	5
9	VEER	Receiver Ground (Common with Transmitter Ground)	1
10	VEER	Receiver Ground (Common with Transmitter Ground)	1

11	VEER	Receiver Ground (Common with Transmitter Ground)	1
12	RD-	Receiver Inverted DATA out. AC Coupled	
13	RD+	Receiver Non-inverted DATA out. AC Coupled	
14	VEER	Receiver Ground (Common with Transmitter Ground)	1
15	VCCR	Receiver Power Supply	
16	VCCT	Transmitter Power Supply	
17	VEET	Transmitter Ground (Common with Receiver Ground)	1
18	TD+	Transmitter Non-Inverted DATA in. AC Coupled.	
19	TD-	Transmitter Inverted DATA in. AC Coupled.	
20	VEET	Transmitter Ground (Common with Receiver Ground)	1

Notes:

- Circuit ground is internally isolated from chassis ground.
- Laser output disabled on TDIS >2.0V or open, enabled on TDIS <0.8V.
- Should be pulled up with 4.7k - 10kohms on host board to a voltage between 2.0V and 3.6V. MOD_DEF (0) pulls line low to indicate module is plugged in.
- This is an optional input used to control the receiver bandwidth for compatibility with multiple data rates (most likely Fiber Channel 1x and 2x Rates). If implemented, the input will be internally pulled down with > 30kΩ resistor. The input states are:
 - Low (0 – 0.8V): Reduced Bandwidth
 - (>0.8, < 2.0V): Undefined
 - High (2.0 – 3.465V): Full Bandwidth
 - Open: Reduced Bandwidth
- LOS is open collector output should be pulled up with 4.7k - 10kohms on host board to a voltage between 2.0V and 3.6V. Logic 0 indicates normal operation; logic 1 indicates loss of signal.

5. Electrical Characteristics

The following electrical characteristics are defined over the Recommended Operating Environment unless otherwise specified.

Parameter	Symbol	Min.	Typical	Max	Unit	Notes
Power Consumption	P			0.95	W	commercial
				1.00		Industrial
Supply Current	Icc			280	mA	commercial

				300		Industrial
Transmitter						
Single-ended Input Voltage Tolerance	V _{CC}	-0.3		4.0	V	
Differential Input Voltage Swing	V _{in,pp}	200		240 0	mVpp	
Differential Input Impedance	Z _{in}	90	100	110	Ohm	
Transmit Disable Assert Time				5	us	
Transmit Disable Voltage	V _{dis}	V _{CC} -1.3		V _{CC}	V	
Transmit Enable Voltage	V _{en}	V _{EE} -0.3		0.8	V	
Receiver						
Differential Output Voltage Swing	V _{out,pp}	500		900	mVpp	
Differential Output Impedance	Z _{out}	90	100	110	Ohm	
Data output rise/fall time	Tr/Tf		100		ps	20% to 80%
LOS Assert Voltage	V _{losH}	V _{CC} -1.3		V _{CC}	V	
LOS De-assert Voltage	V _{losL}	V _{EE} -0.3		0.8	V	

6. Optical Characteristics

The following optical characteristics are defined over the Recommended Operating Environment unless otherwise specified.

Parameter	Symbol	Min.	Typical	Max	Unit	Notes
Transmitter						
Center Wavelength	λ_c	1530	1550	1570	nm	
Spectrum Bandwidth(RMS)	σ			1	nm	
Side Mode Suppression Ratio	SMSR	30			dB	
Average Optical Power	P _{AVG}	1		6	dBm	1

Optical Extinction Ratio	ER	9			dB	
Transmitter OFF Output Power	POff			-45	dBm	
Transmitter Eye Mask		Compliant with 802.3z(class 1 laser safety)				2
Receiver						
Center Wavelength	λ_c	1470	1490	1510	nm	
Receiver Sensitivity (Average Power)	Sen.			-33	dBm	3
Input Saturation Power (overload)	Psat	-10			dBm	
LOS Assert	LOSA	-41			dB	4
LOS De-assert	LOSD			-34	dBm	4
LOS Hysteresis	LOSH	0.5	2	6	dBm	

Notes:

1. Measure at 2⁷-1 NRZ PRBS pattern
2. Transmitter eye mask definition.
3. Measured with Light source 1550nm, ER=9dB; BER =<10⁻¹² @PRBS=2⁷-1 NRZ
4. When LOS de-asserted, the RX data+/- output is High-level (fixed).

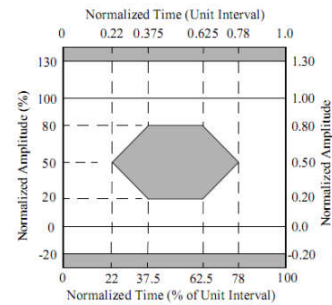

7. Digital Diagnostic Functions

The following digital diagnostic characteristics are defined over the Recommended Operating Environment unless otherwise specified. It is compliant to SFF8472 Rev10.2 with internal calibration mode. For external calibration mode please contact our sales staff.

Parameter	Symbol	Min.	Max	Unit	Notes
Temperature monitor absolute error	DMI_Temp	-3	3	degC	Over operating temp
Supply voltage monitor absolute error	DMI_VCC	-0.15	0.15	V	Full operating range
RX power monitor absolute error	DMI_RX	-3	3	dB	

Bias current monitor	DMI_bias	-10%	10%	mA	
TX power monitor absolute error	DMI_TX	-3	3	dB	

8. Mechanical Dimensions

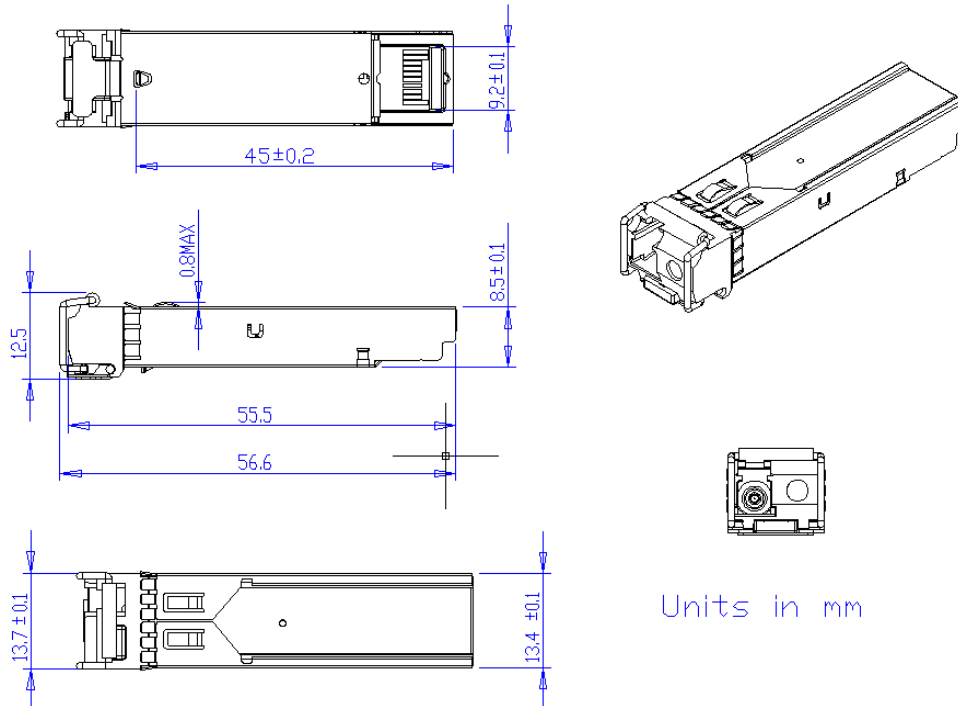

Figure2. Mechanical Outline